



**KIHEUNG MACHINERY CO.,LTD**

대전광역시 대덕구 문평동 43-1

TEL : 042) 933-5500~4 FAX : 042) 933-5505 Web : www.kiheung.com E-mail : kiheung@kiheung.com

43-1 Moon Pyung-Dong, Dae Deog-Ku, Taejeon, Korea

TEL : 82-42-933-5500~4 FAX : 82-42-933-5505 Web : www.kiheung.com E-mail : mkchang@kiheung.com

# RTW1000

BED TYPE T-MILLING CENTER with ROTARY TABLE

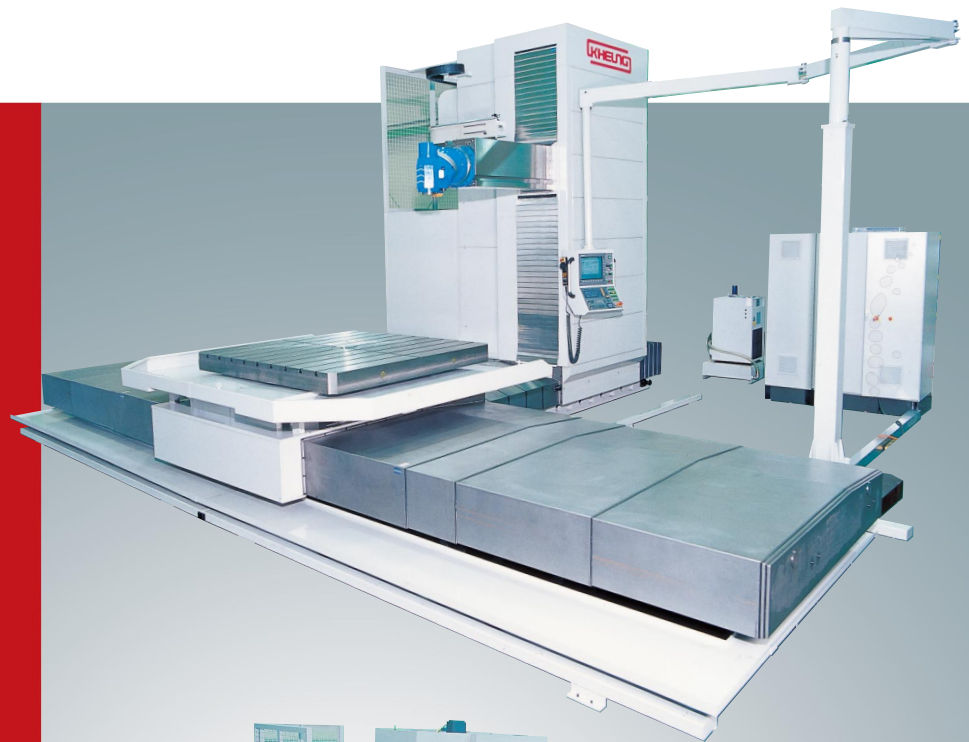



**KIHEUNG MACHINERY CO., LTD**  
MILLING MACHINE / MACHINING CENTER / COLUMN TRAVEL

# KIHEUNG ENDEAVOURS TO OFFER THE ULTIMATE TO CUSTOMERS THROUGHOUT THE WORLD.

Since founded in 1968, KIHEUNG has become one of the most advanced and leading machine tool manufacturers with an effort to supply high quality product to customers.

KIHEUNG specialized in CNC bed type milling machine, travelling column boring and milling center, Double column machining center, Simultaneous five axis machining center, Double column 5 axis and vertical turning machine, is determined to enhance the quality by respecting the customer's requirements with the philosophy of

“FULL SATISFACTION TO THE CUSTOMER  
AND  
ENDLESS SERVICE TO THE CUSTOMER”

Through the spirit of mutual co-operation, KIHEUNG is able to ensure the continuous distribution with high quality machine tools designed to satisfy customer's requirements all over the world. Thanking and trusting in your continuous support.

## KIHEUNG History

- 1968 KIHEUNG machinery works founded
- 1978 Developed conventional bed type milling machine
- 1989 KIHEUNG foundry Co. established  
Start to exhibit EMO exhibition
- 1990 Developed CNC bed type milling machine
- 1995 The current plant(20,000 m<sup>2</sup>) established in Daejeon, Korea
- 1996 CE certificate from TÜV, Germany
- 2002 KIHEUNG USA established
- 2003 Awarded ISO 9001 certificate
- 2004 Developed double column machining center, MiMAX
- 2005 Developed simultaneous 5 axis machining center, FTV 500
- 2006 Developed column travel boring and milling center, HiTRAX
- 2007 Developed double column 5 axis and vertical turning machine, FTU 1200
- 2008 KIEHUNG Germany established  
Developed fixed bed column travel boring and milling center, RiGiTRAX
- 2009 Awarded 20 million dollar export prize from Korea government
- 2010 Developed column travel boring and milling center, WiNGTRAX



# BED TYPE T-MILLING CENTER with ROTARY TABLE

# RTW1000



Machine Specification		RTW 1000	
<b>ROTARY TABLE</b>	Surface	1800~2200 × 1800~2200 mm	3000 × 2000 mm
	T-slots	8 × 22 mm H12, 1 × 22 mm H7	
	Distance between T-slots	200 mm	
	Max. permissible load	15ton / 20 ton	20 ton
	Table auto indexing, Continuous	0.001°	
<b>TRAVEL</b>	Longitudinal travel	3000 / 4000 / 5000 / 6000 mm	
	Cross travel : Ram	1350 / 1500 mm	
	Column	1200 / 1500 / 2000 mm	
	Vertical travel	1600 / 2000 / 2500 mm	
<b>FEED</b>	Axis feedrate	X, Y, Z : 8000, W : 5000 mm/min	
	Rapid feedrate	X, Y, Z : 16000, W : 10000 mm / min C : 4 rpm / 15 ton, 3 rpm / 20 ton	
<b>SPINDLE</b>	Taper	50	
	Speed	4000(2 steps : 0~1000, 1001~4000)	
<b>MOTOR</b>	Spindle drive motor	28 / 42 kw	
	Feed drive motor	X : 70, Y : 27, Z : 50, C : 70, W : 50 / 70 Nm	
<b>WEIGHT</b>	Approx. machine net wieght	40~60 ton	

The contents of the catalogue are subject to change without prior notice.

■ **T-Milling with 5 (five) face**

Double work scope due to column cross and ram cross movement  
Column cross movement till 2000mm and Ram cross movement till 1500mm performs 5(five) face machining of the big and long work piece efficiently with high accuracy.

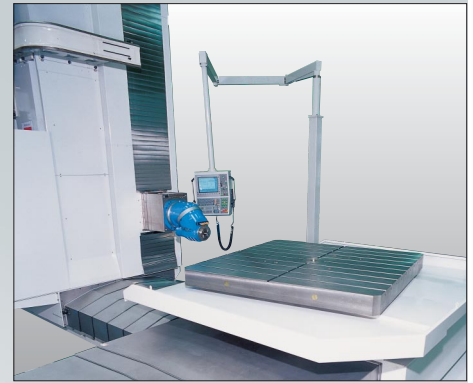
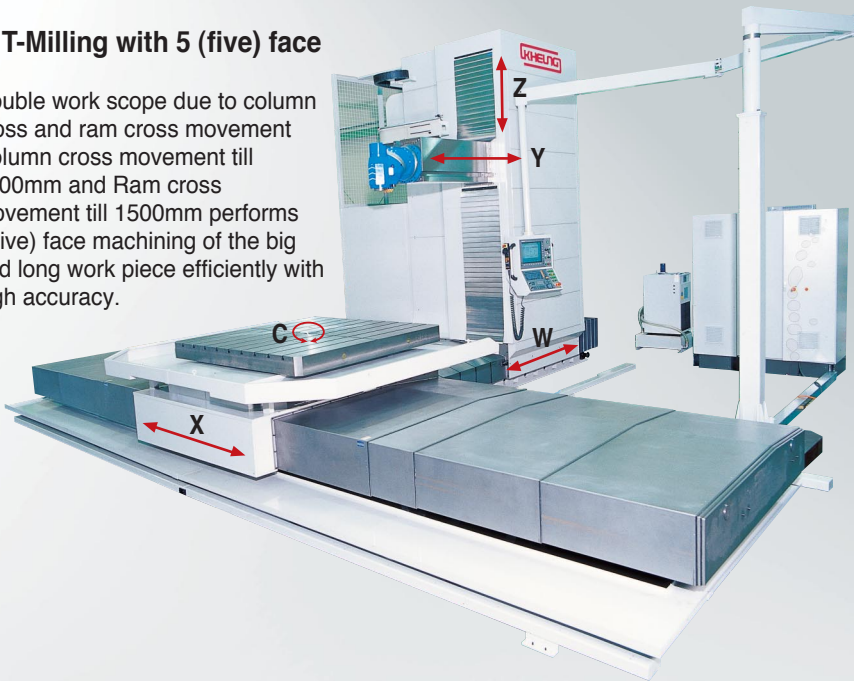

■ **Easy approach for horizontal work**

Operator can work conveniently in horizontal position by approaching easily with 2(two) door.



■ **Column + Ram forward**



■ **Column + Ram backward**

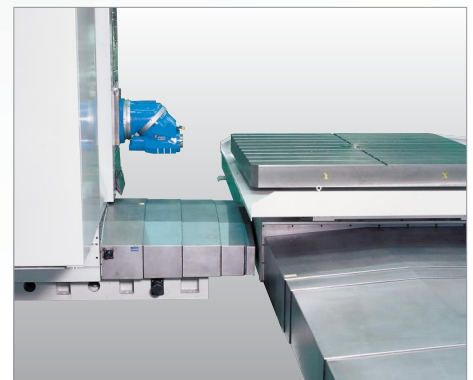

# BED TYPE T-MILLING CENTER with ROTARY TABLE

## RTW1000

### Bed type T - Milling Center

X=3000~6000mm, Y=1350 / 1500mm,  
Z=1600~2500mm

#### ■ Standard

- Heideanhin iTNC530 BF150 CNC with smart TNC. Mouse pad and DXF converter.
- Heidenhain or Siemens spindle motor 28 / 42 kw
- Heidenhain or Siemens AC servo motor
- Heidenhain linear scale
- Heidenhain electronic hand wheel HR410
- Heidenhain DA300
- Fibro rotary table 0.001° auto indexing
- ZF gear box, 2 step (1~1000, 1001~4000 rpm)
- Universal head
- Spindle orientation for rigid tapping
- Hydraulic balance for vertical Z axis
- Automatic centralized lubrication system with pressure switch
- Flood coolant system  
The quantity of coolant water is adjusted by potention meter on the operator panel
- Oil cooler for cooling the head and ZF gear box
- 2(Two) sliding door in front and 2(two) sliding door at rear for CE norm
- Telescopic chip cover for X, multi cover for Z axis
- Preparation of TS220 work piece touch probe
- Spindle air blast for A2, A4 head with automatic tool change
- Air blow through nozzle
- Automatic power off





### ■ Flat-Ram design

Flat-Ram design can not be disturbed with “inside-works”, because all the transmission equipments (ZF gear box, Belt / Pulley) are located at the rear of the ram.

Furthermore, all the chips and coolant water can be protected perfectly and conveyed to the chip reservoir and coolant tank effectively.



### ■ Universal Head

Universal head consisting of upper head and lower head can be turned to desired angle, which is suitable for combined angle milling.



### ■ High Quality Component

- CNC : Heidenhain, Siemens, Fanuc
- Motor : Heidenhain, Siemens, Fanuc
- Rotary table : Fibro, Germany
- Spiral bevel gear for universal head : Tandler, Germany
- Spindle bearing : SKF, Sweden
- Spindle gear box : ZF, Germany
- Ball screw for X, Y, Z, W axis : Korta, Spain
- Roller shoes and guide way for vertical axis : INA, Germany
- Lubrication pump : Dropsa, Italy
- Hydraulic unit : HAWE, Germany
- Electric component : Telemecanique / Schneider, Germany
- Electric cabinet : Rittal, Germany

# BED TYPE T-MILLING CENTER with ROTARY TABLE

# RTW1000

## KIHEUNG Quality Machine

KIHEUNG's every machine is tested with 100% actual machining to check the cutting power.

Furthermore, geometric accuracy is tested during assembly and after assembly.

Final geometric accuracy test report is delivered together with the machine.

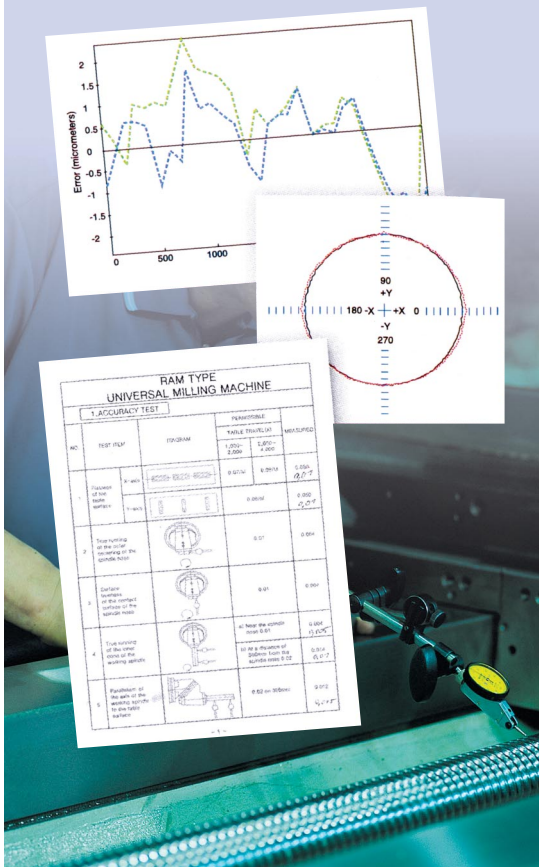

### Ram

8-faces with 4 ground way and 4 gib way for a high milling performance and geometric accuracy during critical maximum Y cross travel.

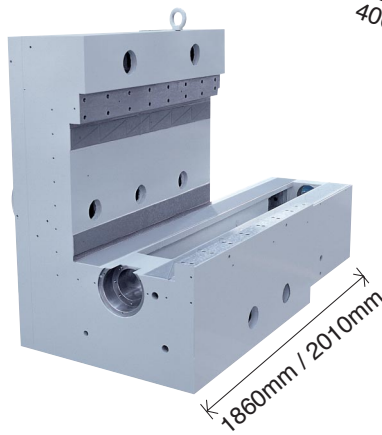
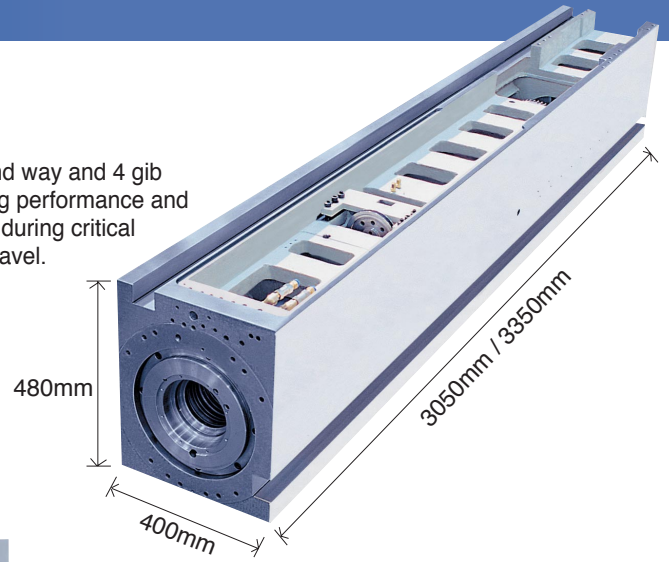

### Saddle for cross movement

Saddle with 1860mm / 2010mm guide way length, which is long enough to prevent "ram drooping", guarantees geometric accuracy during critical maximum Y cross travel.

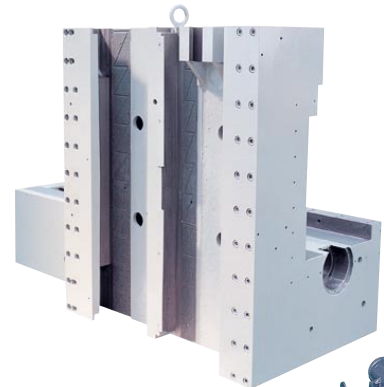

### Saddle for vertical movement

Saddle with 3 turcite guide way and 1 gib way in combination with 2 INA roller shoes reduces "stick-slip" and reaches to the "damping effect" for the smooth vertical movement.

Furthermore, it prevents saddle deviation during critical maximum Y cross travel.

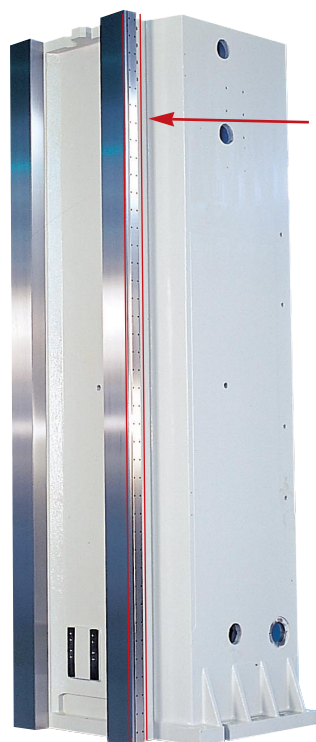

INA steel

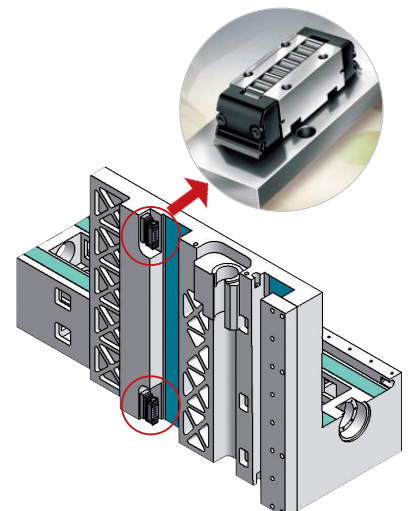

### ■ Column base

Strong column base with wide slide way (250mm) and  $\varnothing$  100mm ball screw and big motor

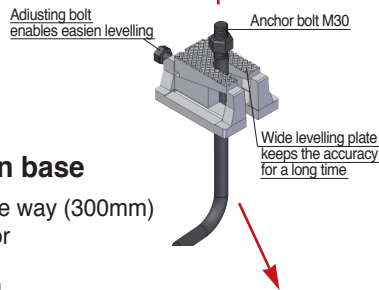

### ■ Rotary table base + Column base

Strong rotary table base with wide slide way (300mm) and  $\varnothing$  100mm ball screw and big motor



### ■ Rotary table 3000 × 2000 mm

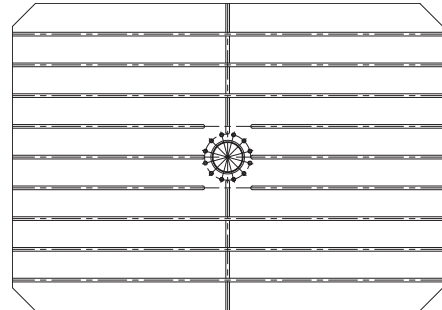

Table size	3000 × 2000 mm
T-slot	8 × 22 H12, 1 × 22 H7
Distance between T-slot	200 mm
Max. Permissible load	20 ton
Max. Table speed	3 rpm
Tangential moment	40000 Nm
Hydraulic clamping	64 bar
Table auto indexing	0.001°



Korea / Germany

**FIBRO**

**Kiheung bed type T-milling Center with Fibro rotary table**

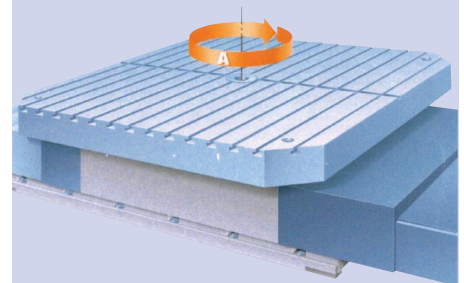

### ■ LM-Ball screw support system for X 4000, 5000 and 6000mm

LM Ball screw support system reduces ball screw vibration and enables smooth movement of table and heavy work piece without stick-slip.

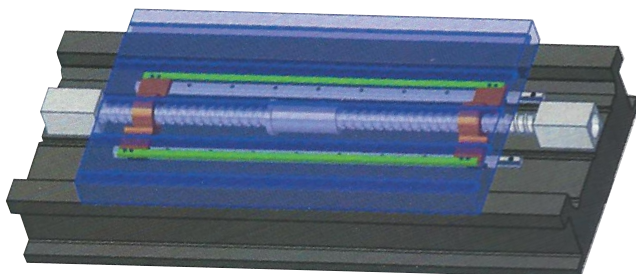

### ■ Hand Scrapping

The accuracy of RTW1000 is guaranteed by the craft man's art of scrapping measured in micron.

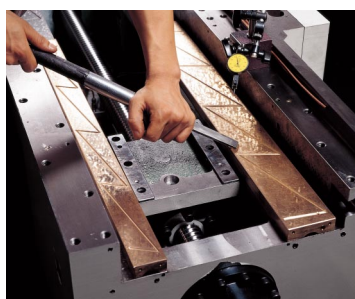

- High precision worm gear and worm screw
- Big INA YRT bearing
- Hydraulic clamping : 64 bar
- Positioning accuracy  $\pm 3$  arc sec with direct measuring system (Heidenhain encoder) for 0.001° auto indexing

# BED TYPE T-MILLING CENTER with ROTARY TABLE RTW1000

## KIHEUNG Foundry

The material used for KIHEUNG's all major and critical parts, such as base, column, saddle, table, ram and head is made by KIHEUNG Foundry.

## High-Quality Cast iron

KIHEUNG cast iron has the advantage both thick and thin parts have the same properties after cooling.

KIHEUNG's techniques through control of the casting process permits the production of reliable, high quality material with no defects such as shrinkage cavities, coarse crystal structure and keep on maintaining accuracy for a long time.

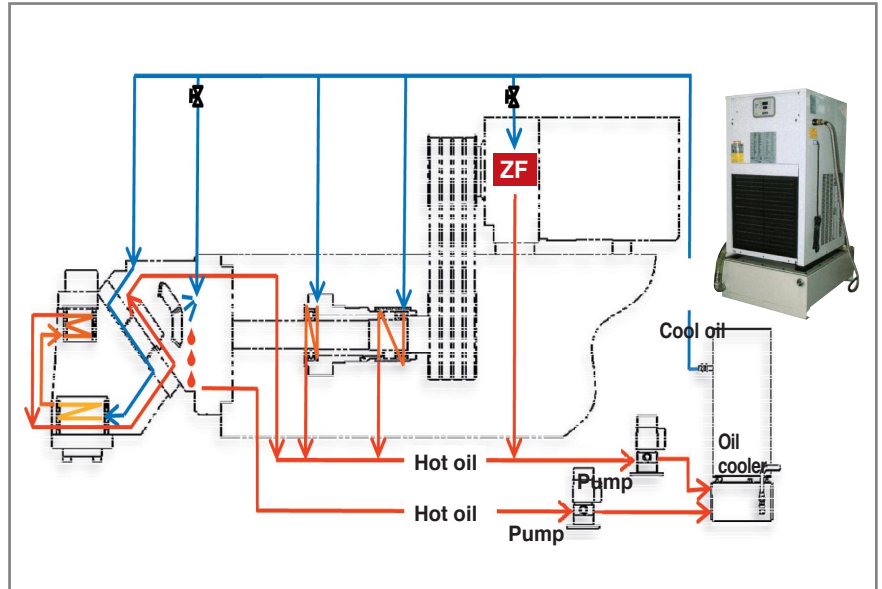

### Oil cooling

Head and ZF gear box is cooled by oil cooler.

Hot oil inside the upper head (90°) and ZF gear box is delivered quickly to the oil cooler through 2 (two) pumps on the ram.

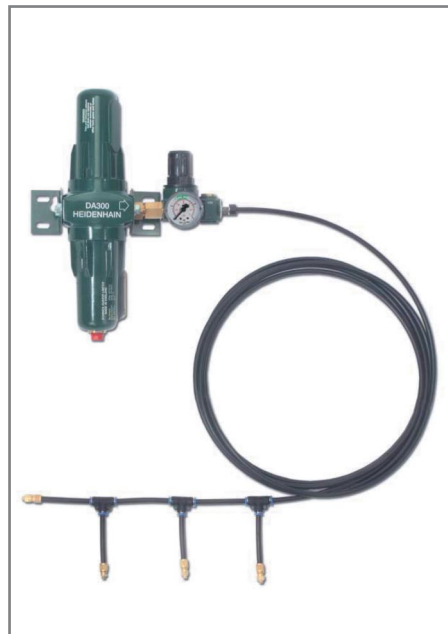

### Heidenhain DA300

Heidenhain DA300 enables to supply the clean air to 3 axis Heidenhain linear scale.

It protects Heidenhain linear scale from dust, small chips and coolant water.

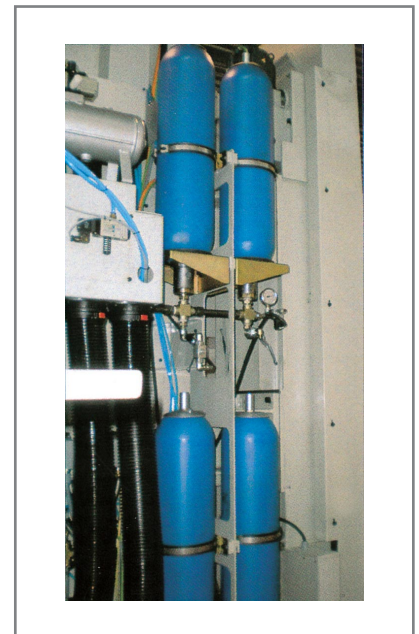

### Hydraulic Balance

Hydraulic balance with Nitrogen gas accumulator guarantees smooth movement and high accuracy of vertical Z axis

# Option

## ■ A2 Head (Automatic 2 positioning, Vertical / Horizontal)

- ISO50 DIN69871
- Hydraulic tool clamp / unclamp
- 4000 spindle rpm with cooling the head (2step, 0~1000, 1001~4000)

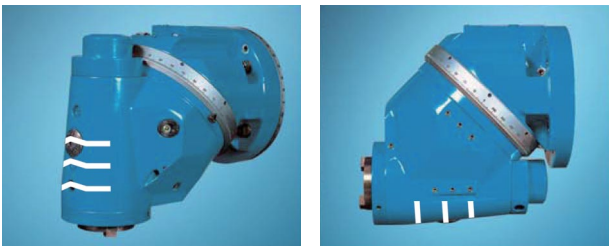

## ■ A4 Head (Automatic 2.5° × 2.5°) A4 Head (Automatic 2.5° × 1°)

- ISO50 DIN69871
- Hydraulic tool clamp / unclamp
- 4000 spindle rpm with cooling the head (2step, 0~1000, 1001~4000)

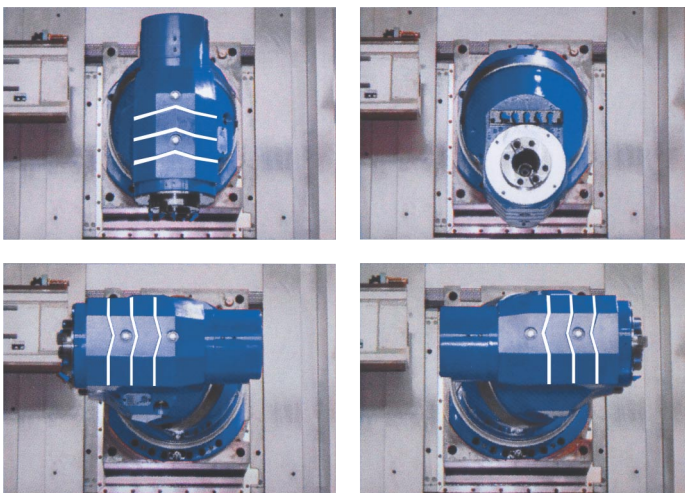

## ■ Tool touch probe HEIDENHAIN TT140 with air operated cover

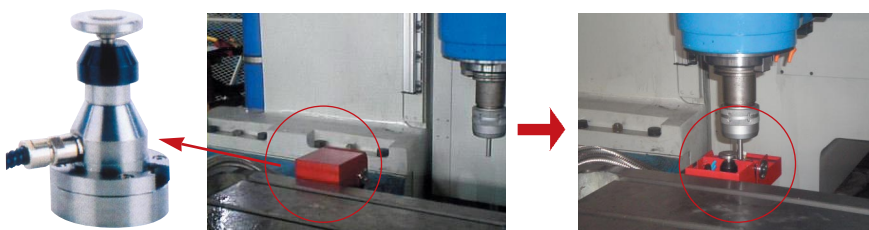

# Option

## Tool touch probe HEIDENHAIN TT140

with cable connection for tool length and radius compensation with stationary or rotating spindle



## Work piece touch probe HEIDENHAIN TS220

for releasing a trigger signal to the iTNC 530 control through cable



## Work piece touch probe HEIDENHAIN TS640

for releasing a trigger signal to the iTNC 530 control as an infrared light signal



## Work piece touch probe RENISHAW RMP 60

with radio signal transmission



# BED TYPE T-MILLING CENTER with ROTARY TABLE

## RTW1000

### Option

#### ■ Coolant through Spindle

##### 1. CTS - Cartridge filter

- 16 bar coolant through spindle  
9 bar coolant through nozzle
  - Tank volume 500 ℓ
- Dual cartridge filter (20 μm) to switch over when one filter is dirty

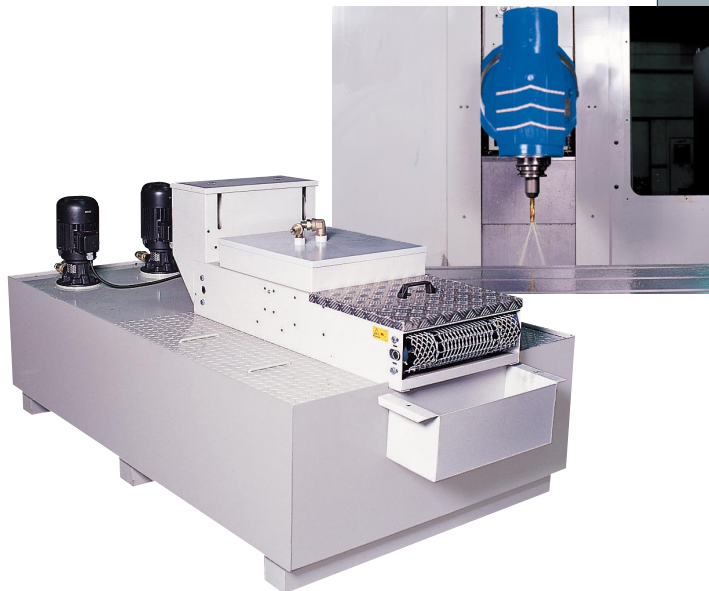
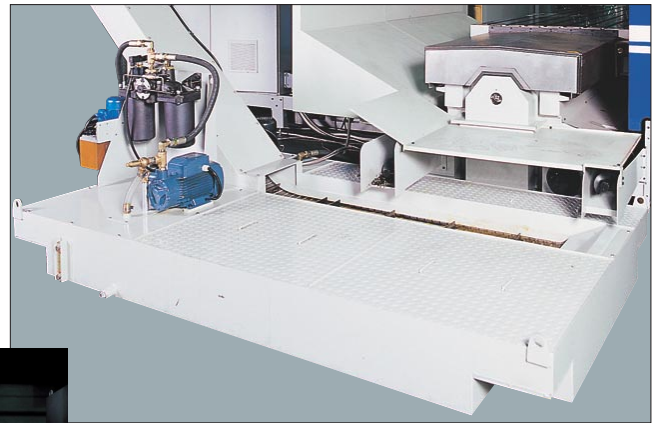

##### 2. CTS - Paper filter

- 16 / 30 bar coolant through spindle  
9 bar coolant through nozzle
- 2 (two) Tanks : 1 (one) dirty tank volume 500 ℓ  
1 (one) clean tank 1200 ℓ
- Paper band filtering (10 μm) system with drive and paper transport unit

#### ■ Direct Horizontal Spindle Head

: 2 step gear change

#### ■ Sub. Angle Table

1300(H) × 1100 × 625mm

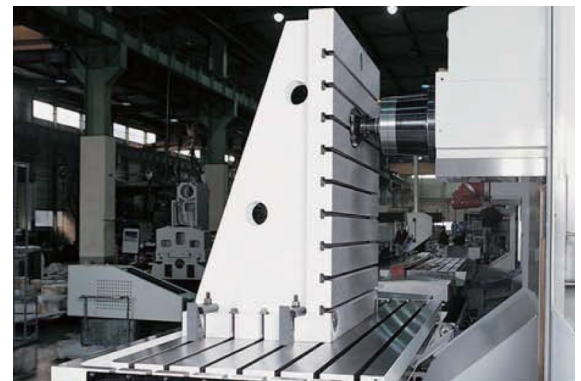

#### ■ Lift up chip conveyor (Front, Rear)

Wider link type chip conveyor performs "QUICK EXTRACTION" of chips and coolant water to the bucket and tank.

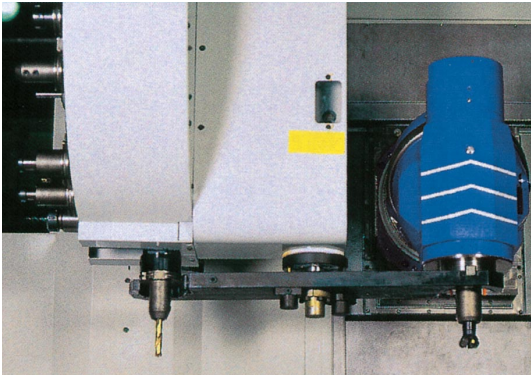

### ■ 24 Tools Vertical ATC

Cam and cam follower automatic tool changer driven by geared motor

Max. tool weight	kg	20
Max. tool length	mm	350
Max. tool diameter $\varnothing$		
- when adjacent tool present	mm	110
- when adjacent tool absent	mm	200

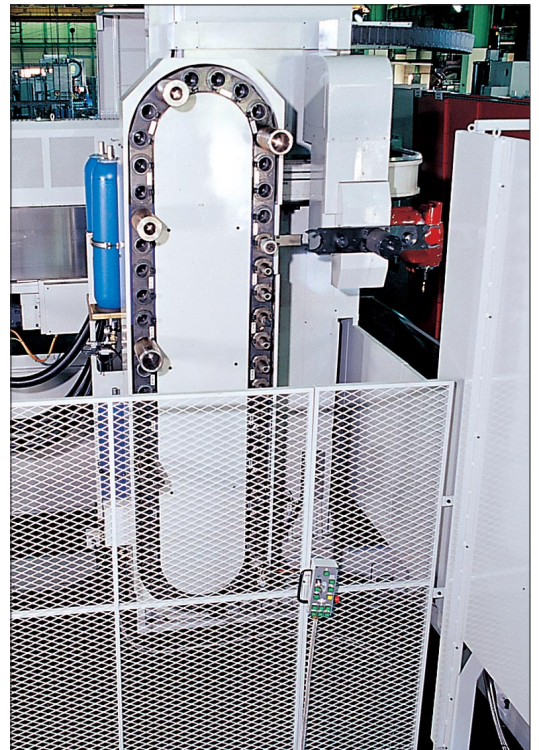
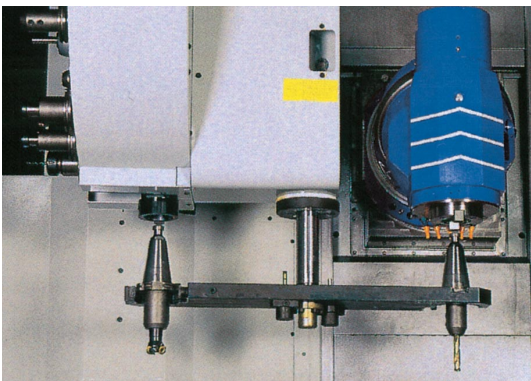

### ■ 30 / 40 / 50 / 60 / 90 Tools Vertical / Horizontal ATC

Chain type tool magazine driven by servo motor.

Carriage and gripper is operated by hydraulic system.

Max. tool weight	kg	25
Max. tool length	mm	350
Max. tool diameter $\varnothing$		
- when adjacent tool present	mm	125
- when adjacent tool absent	mm	250

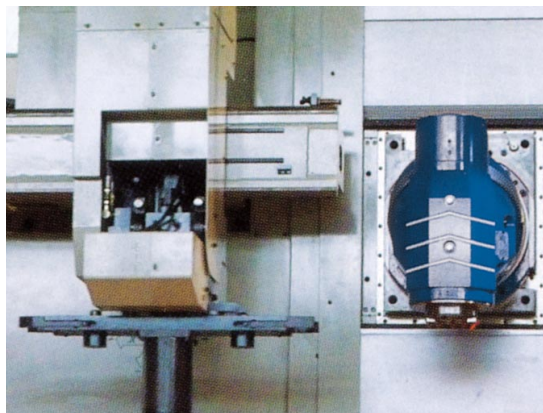
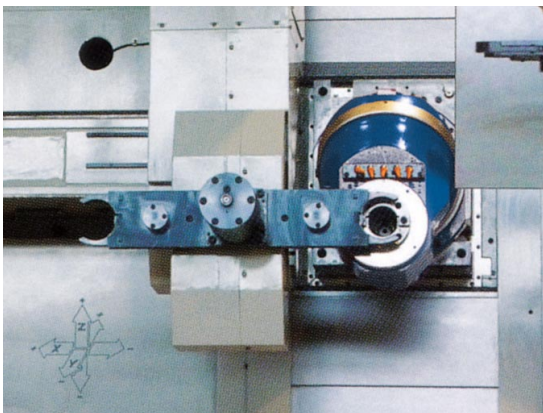

# BED TYPE T-MILLING CENTER with ROTARY TABLE

## RTW1000

### RTW 1000

Table : 1800 / 2000 / 2200 × 1800 / 2000 / 2200mm

3000 × 2000mm

X Axis : 3000 / 4000 / 5000 / 6000mm

Y Axis : 1350 / 1500mm

Z Axis : 1600 / 2000 / 2500mm

W Axis : 1200 / 1500 / 2000mm

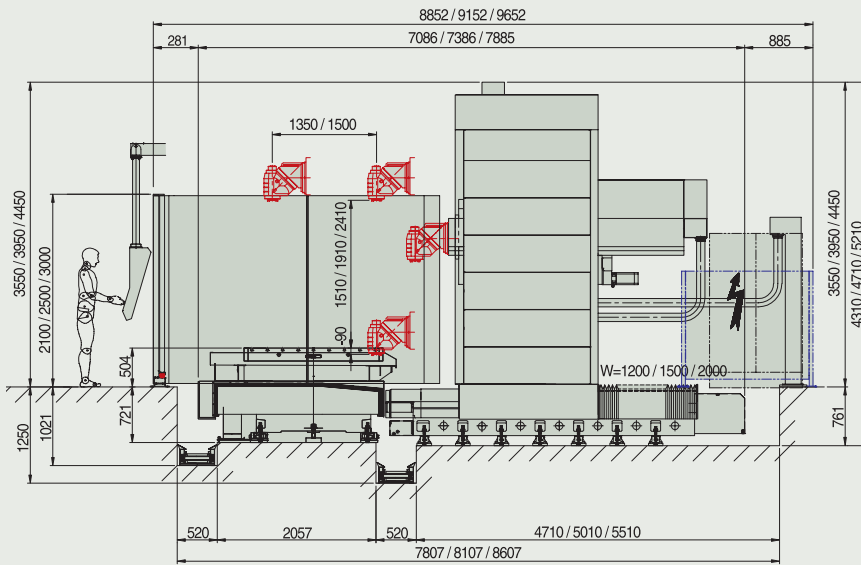

### Spindle Motor

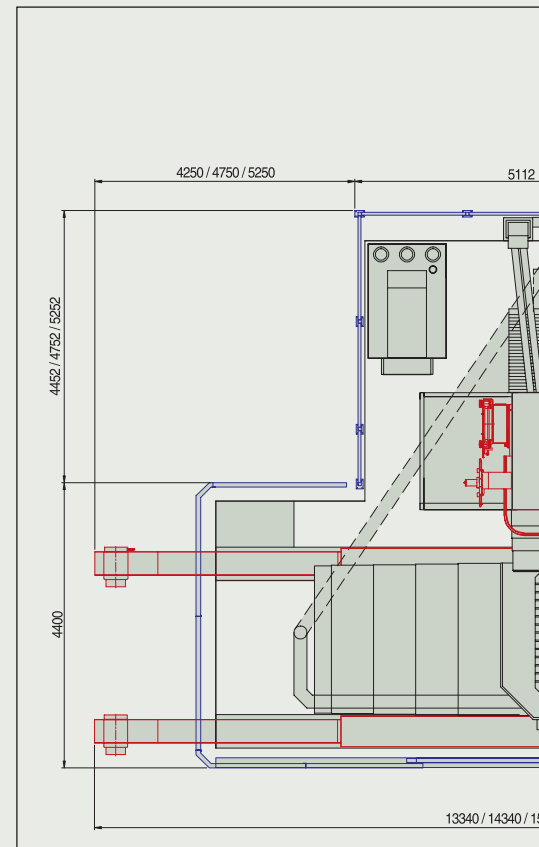
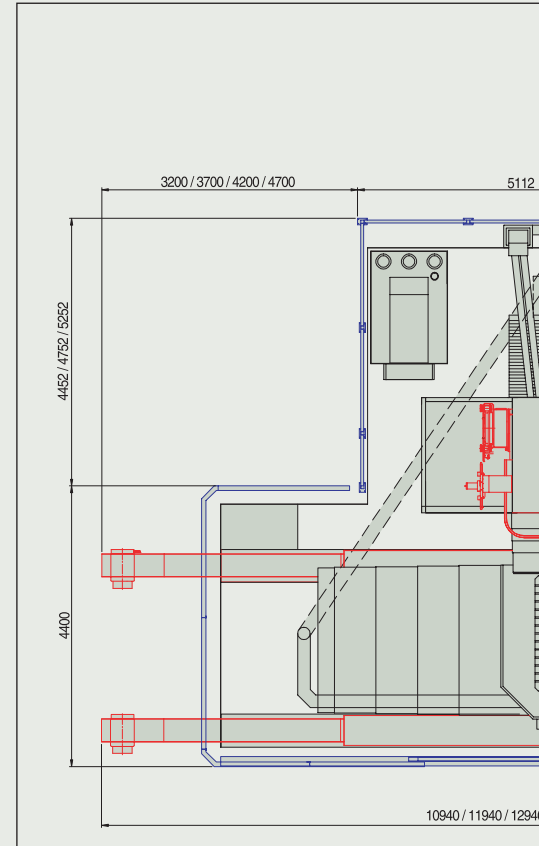
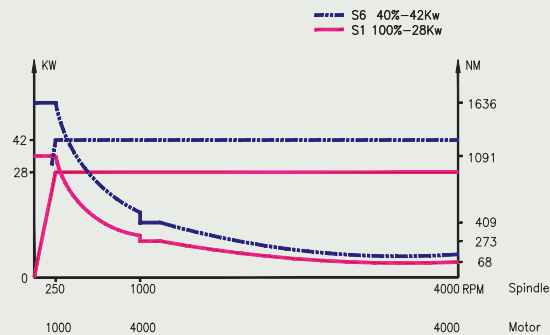

**RTW 1000**

Table 1800 / 2000 / 2200 × 1800 / 2000 / 2200mm  
X Axis : 3000 / 4000 / 5000 / 6000mm

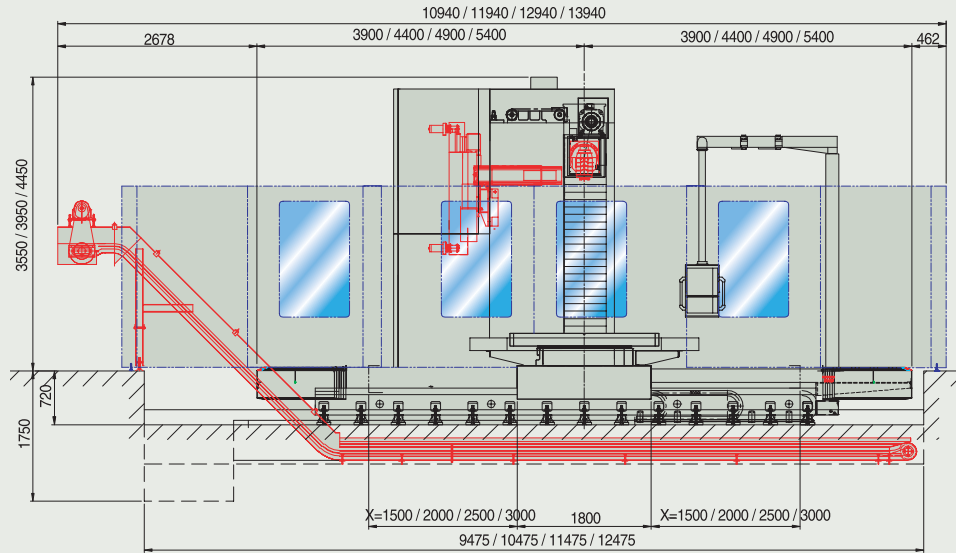
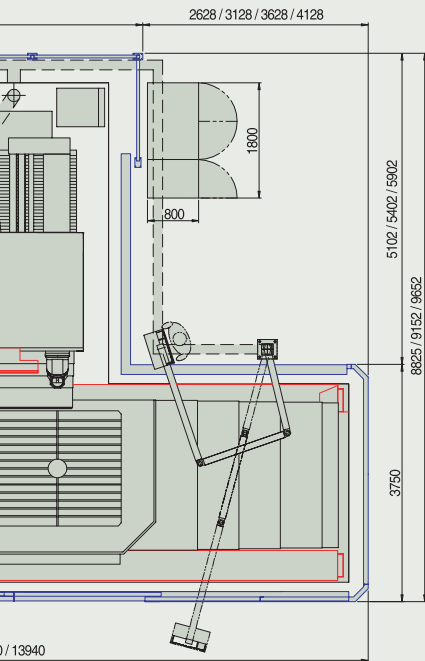

**RTW 1000**

Table 3000 × 2000mm  
X Axis : 4000 / 5000 / 6000mm

